

CKC

Pinspot 40

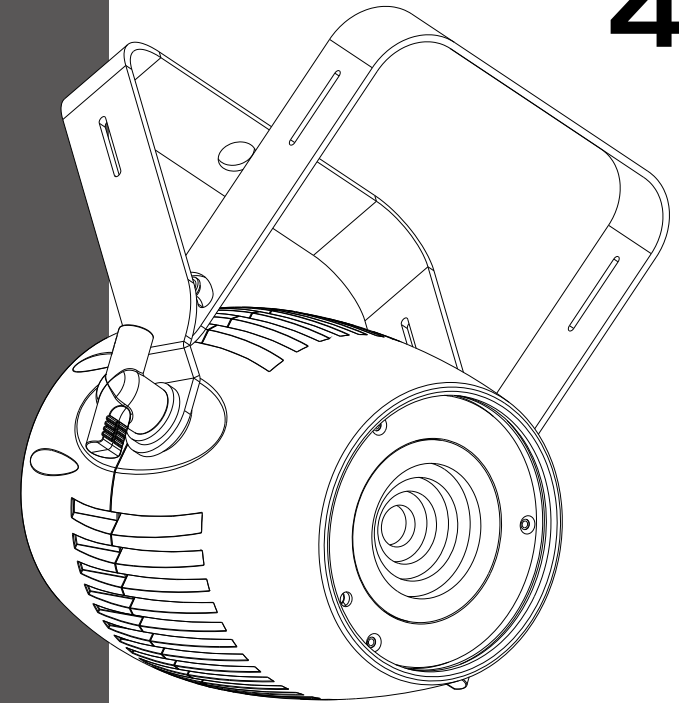

www.ckclighting.com

CKC LIGHTING CO.,LTD

Addr.:335 Nansha Avenue, Tung Chung Town,
Nansha District, Guangzhou City, China.
TEL: (020)3920 4506 FAX: (020)3920 4631
WEB: www.ckclighting.com



Before carrying out any installation, maintenance, or cleaning of the lighting fixtures, please confirm that the power has been cut off! Before using this fixture, please read this manual. Our company reserves the right to change product design and specifications without prior notice.

CONTENTS

1. Security Warning Information	1
2. Product Introduction	3
2.1 Exterior dimensions	3
2.2 Fixture packaging accessories	3
3. Main technical parameters of the equipment	3
4. Packaging and transportation	4
4.1 Disassemble packaging	4
4.2 Equipment installation	4
5. Installation Requirements Explanation	5
5.1 Clamp installation	5
5.2 Fixture installtion	6
5.3 Hanging Installation Diagram	6
5.4 Installation diagram of frost filter	6
6. Power and signal connection	7
6.1 Power and signal socket	7
6.2 Power Connect	7
6.3 Signal Connect	8
7. Control panel	8
7.1 Panel Introduction	8
7.2 System menu	9
8. DMX control channel table	10
9. Control circuit diagram	11
10. Regular maintenance	12
10.1 Cleaning and maintenance	12
10.2 Fault analysis and handling	12

★ Statement ★

- This manual contains important information on safe use and installation. Please read it carefully and follow the requirements for operation and installation. Please keep this manual properly;
- The equipment has good performance and complete packaging when it leaves the factory. The operator should strictly follow the warning items and operating instructions stated in the manual. Any malfunction or damage caused by misuse or neglect of the manual is not within the scope of our company's responsibility and warranty;
- The relevant information in this manual is for reference only. All lighting products are subject to the actual product. Any changes will not be notified separately, and our company reserves the right of final interpretation.

1. Security Warning Information



Attention !

Please read the safety requirements information in this section carefully before installing, powering on, operating, or repairing the lighting fixtures.



- This product is for professional use and is not suitable for other purposes;
- After receiving the lighting fixtures, please check if the packaging is complete and unpack to check if the equipment has been damaged due to transportation. If there is any damage caused by transportation, please do not use this lamp and contact local technicians or manufacturers as soon as possible;
- When transporting again, please use the original packaging materials;
- If there is obvious damage to the machine casing, it should be replaced in a timely manner;
- When hanging lamps, it is necessary to verify that the hanging equipment can withstand more than 6 times the weight of the lamp. After installation, it is necessary to verify that the lamp cover and installation buckle are secure and undamaged. At the same time, a safety rope should be used as an auxiliary safety for the lamp and fixed on the truss;
- The light source inside this luminaire should be replaced by the manufacturer, its service agent, or a similarly qualified person;
- If you have any other questions about how to safely operate the equipment, please contact our technical personnel or call our service hotline;
- This product has a protection level of IP30 and is suitable for indoor use;
- Avoid direct external strong light shining on the lens, which may cause the lens to focus and burn out internal components.



- Lighting fixtures should be kept clean and avoid prolonged use in overheated or dusty environments to prevent contact with chemical liquids;
- When using the product, attention should be paid to avoiding serious or fatal injuries caused by fire, heat, electrical shock, and ultraviolet radiation. Before powering on or installing, read the instruction manual first. Follow the safety precautions for operation and pay attention to the warning signs on the instructions and equipment;
- Only professionals are allowed to install, operate, and maintain lighting fixtures, and strictly follow the procedures stated in the operating instructions.



- The eyes cannot directly look at the luminous object;
- Do not connect this device to any dimmer;
- If visible damage occurs to the protective casing, lens, and display screen on the lighting fixture, it is considered as damage to the point of loss;
- Please do not place any filters or other items at the light outlet, and do not replace non original parts;
- The minimum safe illumination distance of the lamp is 1m.



- Before installation, please confirm that the power supply voltage used matches the voltage indicated on the light fixture. Each lighting fixture should be properly grounded and electrically installed according to relevant standards;
- Please disconnect the power before repairing or cleaning the equipment;
- During the operation of the lighting fixtures, touching the wires is prohibited to prevent electric shock;
- If the external soft cable or wire of this lamp is damaged, the wire should be replaced by the manufacturer, its agent, or a similarly qualified person to avoid danger;
- Avoid flammable liquids, water, or metal conductors from entering the interior of the lamp to prevent electric shock or fire. If any foreign objects enter the lamp, immediately cut off the power supply;
- When multiple lamps are operated in series, the signal lines can be connected in multiple ways, but the power supply must be connected separately.



- The lighting fixtures work normally at -20 °C to 45 °C . When replacing any components or accessories in the equipment, ensure that the power is disconnected to prevent electric shock and injury;
- The maximum surface temperature of the lamp during operation can reach 68°C , please do not touch it with bare hands.



- The lighting fixtures must be installed in a sufficiently ventilated area, at least 0.5m away from adjacent surfaces, to ensure that no ventilation holes are blocked;
- Do not install the lighting fixtures directly on flammable objects;
- The minimum distance between all outer surfaces of the lamp and combustible materials is 0.5m.

2. Product Introduction

2.1 Exterior dimensions of lighting fixtures

184 × 182 × 233 mm

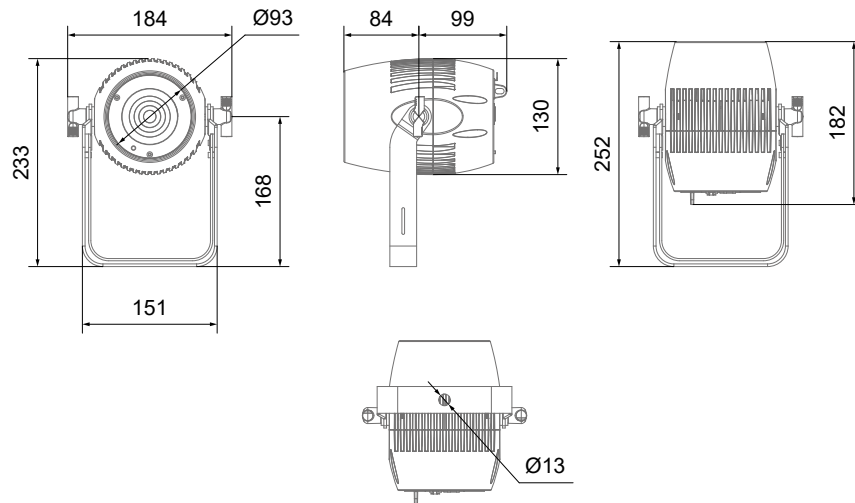

2.2 Packaging accessories

Name	QTY
Clamp	1 PCS
Single-face frost filter	1 PCS
Double-face frost filter	1 PCS
Spring	1 PCS
Safety cable	1 PCS

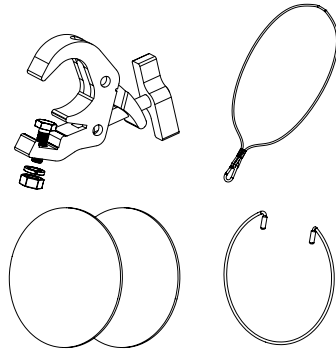

3. Main technical parameters of the equipment

Product execution standards: GB43472-2:2023、GB/T 7000.1-2023、GB/T 7000.217-2023

● Electrical parameter

Rated input voltage: AC 100V-240V~ 50Hz/60Hz
 Rated input power: 45 W
 Power factor: 0.999F
 Input Current: 0.228A 220V

● Source lifespan

> 20000 hours

● Optical system

Source: 40W RGBW LED
 Output luminous flux: 820 Lm
 Beam angle: 4° /6° (Single-face)/21° (Double-face)
 Field angle: 8° /11° (Single-face)/42° (Double-face)

● Control and programming

Control channel: CH01/CH04/CH06/CH07
 Protocol: DMX512, RDM
 Data connect: 3 or 5 pin XLR in/out,

● Illumination draw

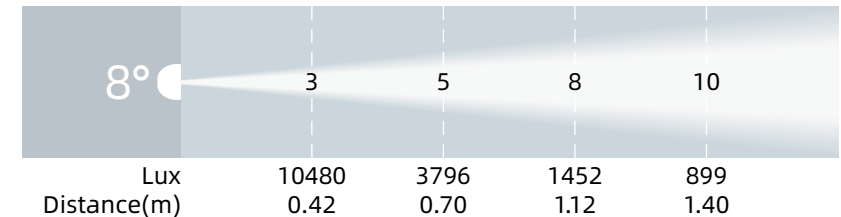

● Other effect function

Fast electronic strobe: 1~25Hz

● Other features and functions

Weight: 2.1 KG

4. Packaging and transportation

4.1 Disassemble packaging

 Notice: After receiving the fixture, please unpack and check for any damage caused by transportation. If there is any damage caused by transportation, please do not use this fixture and contact the local technical personnel or manufacturer as soon as possible.

4.2 Equipment packaging

- 1). Disconnect the power supply before packaging the lighting fixtures to allow them to cool completely;
- 2). Flight cases can only be stacked in two layers and are not allowed to be reversed.

5. Installation Requirements Explanation

5.1 Clamp install

The lighting fixtures can be installed on the stage or on any direction of the truss, and the clamp can be quickly and easily locked onto the truss.

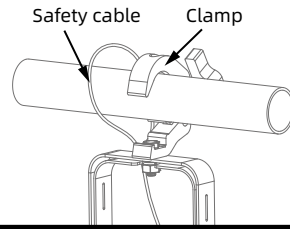

Warning !

Fixture can be used to fix the equipment, and a safety rope must be connected to the safety hook. Note that it cannot be connected to the handle.

Installation of clamps and safety cable

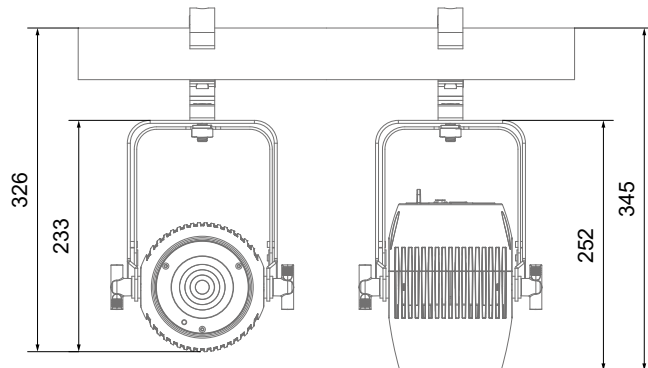
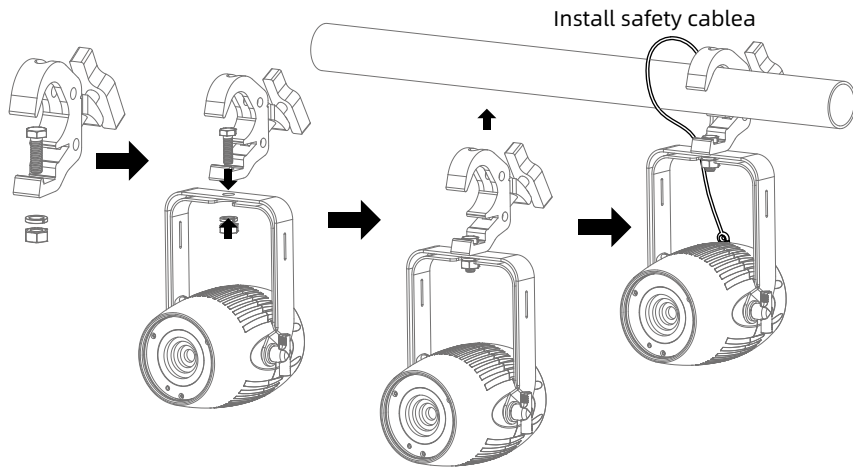

5.2 Equipment installation

- 1). Before installation, it is necessary to verify that the lamp hook and safety rope are not damaged, and that the installation object can withstand 6 times the total weight of the lamp and cable accessories;
- 2). The clamp is installed on the handle. Insert the clamp into the handle mounting hole horizontally and tighten it with bolts (the shape of clamp shall be subject to the actual object)..

5.3 Hanging Installation Diagram

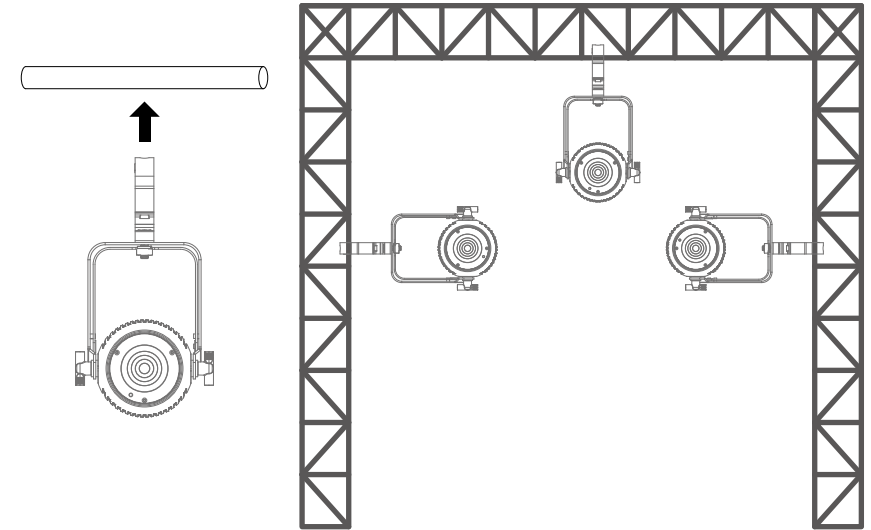

5.4 Installation diagram of frost filter

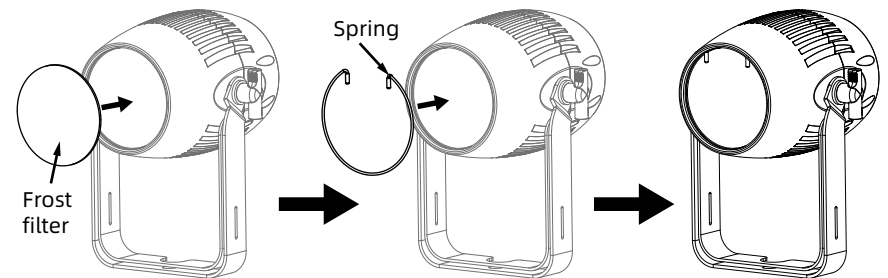

6. Power、Signal connect

6.1 Power and signal socket

1. Power input
2. DMX input
3. Fuse holder
4. DMX output
5. Power output

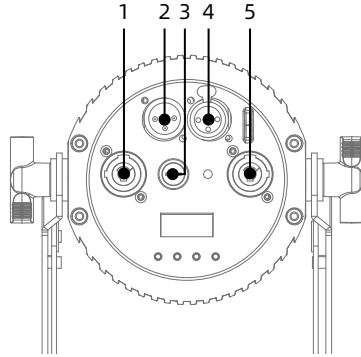

6.2 Power connect

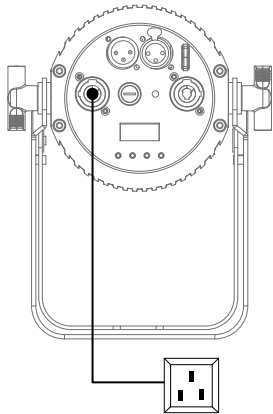

Connection method:

L(live wire) - brown wire

E(Ground wire) - yellow/green dual color line

N(Zero Line) - Blue Line

When connecting the power supply, please note that the voltage and frequency of the power supply must match the voltage and frequency marked on the light fixture. When multiple fixtures are used simultaneously, it is recommended to connect the power supply of each fixture separately, so that each fixture can be individually controlled for power on/off.

⚠ Attention: When connecting the power supply, the ground wire (yellow/green dual color wire) must be safely grounded and comply with all relevant electrical installation standards.



This product uses Powercon In/Out to connect power cords. Due to power limitations, a 2 square meter power cord can carry up to 47 products at 220V and 22 product at 110V.



Warning !

- Do not connect too many fixtures or overload a single power cord;
- Do not use power cords with damaged insulation layers, and do not place power cords on other wires;
- When the fixture is not in use or cleaned, please unplug the power cord; Do not forcefully unplug or drag the power cord directly.

6.3 Signal connect

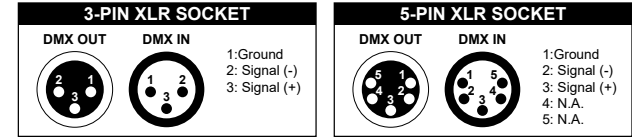

The lighting fixtures are equipped with standard DMX XLR input and output sockets. Please use DMX512 shielded twisted pair signal cables or Category 5 or above network twisted pair cables for connection. The typical connection distance for DMX signal lines is 150 meters. When transmitting signals over long distances, a DMX512 signal amplifier must be added.

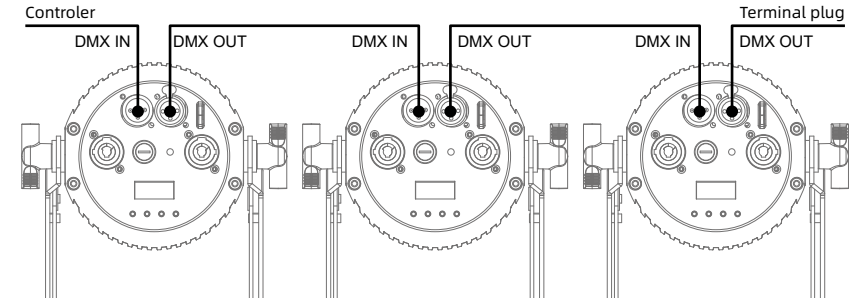

Connect a shielded twisted pair signal cable from the DMX output port of the controller to the DMX input port of the first device, and from the DMX output port of the first device to the DMX input port of the second device, and so on, until all the lamps are connected. Then install a terminal plug on the last 3 or 5 pin socket of each connected lamp output. (Weld a 4/1W, 120 Ω resistor between the 2 and 3 pins of a 3 or 5 core pin XLR plug).

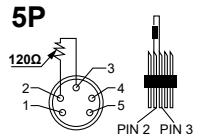
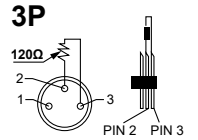

7. Control panel

7.1 Panel Introduction

- Adopting a OLED display screen;
- Press the MODE key to view or modify fixture function settings, and press UP and DOWN;
- Press the ENTER key to confirm your selected function menu, which will take you to the corresponding sub menu in the menu. Each menu item represents a specific function of the lighting fixture (as shown in the table below);
- Press the ENTER key to save your modifications or enter a submenu, and press the UP or DOWN key to modify values (increase or decrease values);
- Press the MODE key to return to the previous menu or exit.

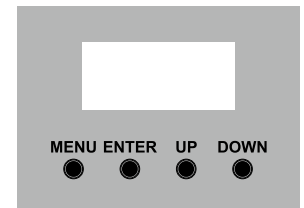

Infrared control function



Button	Functional Description
BLACKOUT	LED light switch
S PR	Enter the built-in program, press --to select
FL	Flashing on and off, press --+speed adjustment to turn on default 50 speed, turn off speed to 0
SP	Speed adjustment, press --to adjust the speed in jump mode and dream mode
D	Enter DMX mode
SA	Enter voice control mode, do not use outdoor waterproof lights in this mode
SL	Slave mode
S,0,1,2,3,4,5,6,7,8,9	Used for address setting
R,G,B,W,A,	Adjust the relevant brightness separately by pressing --+

Example of DMX address design:

For example, to design an address of 245, first press the S key, the light will turn red, then press the 2 key, the light will turn green, then press the 4 key, the light will turn blue, and then press the 5 key. Once the address design is complete, the white light will flash.

7.2、System menu

Software Update Please Wait... Y33301 SOFTWARE V1.02		
1	DMX MODE ADDR 001	001-512
2	CHANNEL CH 07	CH01/CH04/CH06/CH07
3	SLAVE MODE	
4	1.STATIC R 99 G 99	R 00-99 G 00-99 B 00-99 W 00-99 F 00-99
	2.CHANGE SP 50 F 00	SP 01-99 F 00-99
	3.CHANG4 SP 50 F 00	SP 01-99 F 00-99

	4.CHANG4 SP 50 F 00	SP 01-99 F 00-99
5	SOUND SENS 31	00-31
6	IR.REMOTE ON	ON/OFF
7	DIMMER RESP-01	01(No delay)/02(Delay)
8	DMX FAIL HOLD	HOLD BLACKOUT STATIC
9	Calibrate	Password (050)
		Red 000-255
		Green 000-255
		Blue 000-255 White 000-255

8. DMX channel table:

CHANNEL				Value	Function
1	4	6	7		
	1	1	1	0-255	R (000-100%)
	2	2	2	0-255	G (000-100%)
	3	3	3	0-255	B (000-100%)
	4	4	4	0-255	W (000-100%)
1		5	5	0-255	DIMMER (000-100%)
		6	6		Strobe
				000-000	non-functional
				001-005	voice control
				006-010	non-functional
				011-255	Strobe from slow to fast (1Hz-20Hz)
		7	7		Colour Macro
				000-004	non-functional
				005-125	Color transition from slow to fast
				126-255	Color dream from slow to fast

Color macro

Valoues	Makro	Red	Green	Blue	White
000-005	Colour off	0	0	0	0
006-013	Red	255	0	0	0
014-021	Amber	255	112	0	0
022-029	Yellow warm	255	161	0	0
030-037	Yellow	255	198	0	0
038-045	Green	0	255	0	0
046-053	Turquoise	0	255	87	0
054-061	Cyan	0	255	200	0
062-069	Blue	0	0	255	0
070-077	Lavender	235	0	255	0
078-085	Mauve	255	0	100	0
086-093	Magenta	255	0	48	0
094-101	Pink	255	22	70	115
102-109	Warm White	255	133	24	26
110-117	White	255	163	70	255
118-125	Cold White	207	255	255	255

9. Control circuit diagram

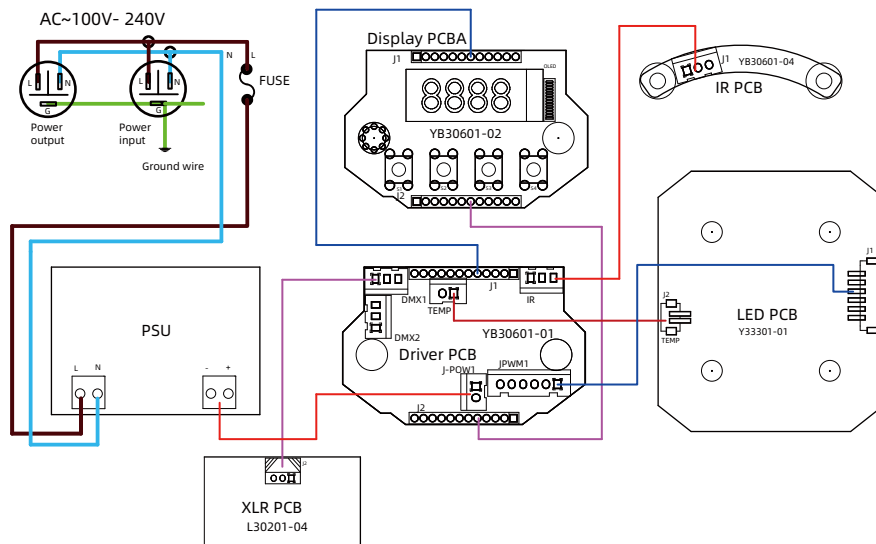

10. Regular maintenance

10.1 Cleaning and maintenance

Lighting fixtures require daily cleaning and maintenance, and their service life largely depends on the operating environment and standards. If you have any questions, please consult our technical engineers for advice. Maintenance and repair work not included in this book should be entrusted to our qualified technical engineers.

Attention! Damage caused by dust, e-liquid, or other reasons, as well as abnormal use, is not covered by the warranty.

**Warning !**

Before opening any lid, disconnect the power supply. Cleaning optical components requires gentle wiping as the coating surface is prone to scratching. Do not use damaging liquids or hard objects, as they may damage the plastic or coating surface.

- When the lens is cracked or otherwise damaged, it should be replaced in a timely manner;
- When the brightness significantly decreases, the LED may have reached its expiration date and should be replaced in a timely manner;
- When the fixture cannot start, please check if the fixture power fuse is blown. If it is blown, a fuse of the same specification must be used for installation;
- The fixture is equipped with a temperature protection device. When the temperature is too high, the protection device will automatically reduce power.
- When this situation occurs, please check whether the fan is running normally, whether the fan and fan mesh are clogged with dust, identify the fault and repair it before starting the fixture. Please note that only qualified technicians are allowed to carry out maintenance work;
- To maintain smooth movement of the focusing lens, it is recommended to lubricate the guide rail of the focusing lens every three months. Excellent and high-temperature resistant lubricating grease should be used, and excessive grease should not be used as it can easily dirty adjacent components.

10.2 Fault analysis and handling

Fault description	Analysis	Processing method
No action after power on	Check if the power switch is turned on	Turn on
	Check if the fuse is blown	Replace
	Check if the output of PSU is normal	Detecting voltage
	Check if poor contact in the internal circuit	Reconnect

Uncontrolled lighting fixtures	Check if the DMX signal cable is connected correctly (If there is no signal, the display screen will flash)	Reconnect or replace
	Check if the address code is correct and if the DMX mode of the lighting fixture matches the settings	Reconfirm
	The main control PCB is damaged	Replace
Not bright	LED aging or damage	Replace
	Power PCB malfunction	Check/ Replace
	Loose or poor contact of the circuit	Reconnect
	PSU malfunction	Replace
Automatically turn off or dim the lights	LED aging	Replace
	The temperature control switch is damaged	Replace
Weak light efficiency and uneven light spot	LED aging	Replace
	The optical mirror has accumulated dust or stains	Clean
	The optical mirror is damaged	Replace
Impure color	Weakening of light efficiency	Replace led PCB
	The color filter has accumulated dust or stains	Clean
	The color filter has been demolded or damaged	Replace
 Attention! The above analysis is for abnormal reference only. Non professionals are not allowed to disassemble and repair the machine		